

TS 5000 ISM

DE, EN, FR, ES



161091-00

GEZE

| | |
|---|---|
| DE Deutsch | 3 |
| EN English | 3 |
| FR Français | 3 |
| ES Español | 3 |
|  | 4 |

DE | Deutsch

Produktbeschreibung

Die TS 5000 ISM Gleitschiene ist für die Montage an zwei-flügeligen Feuer- und Rauchschutztüren zugelassen. Die Anlage enthält eine integrierte Schließfolgeregelung. Ausstattung mit TS 5000 EFS am Gangflügel möglich.

Montagehinweise

Die folgenden Hinweise verstehen sich ergänzend zu den Arbeitsschritten der zugehörigen grafischen Montageanleitung.

- zu **1** ▶ Befestigungslöcher für Schließer und Gleitschiene bohren.
- zu **4** ▶ Drahtseil der Schließfolgeregelung verlegen.
- zu **6** ▶ Scheibe und Kerbe müssen in einer in einer Flucht liegen. Darauf achten, dass das Drahtseil nicht eingeklemmt wird.
- zu **8** ▶ Schrauben nur leicht lösen. Anschlagstange darf nicht unter den Mitnehmer kippen.

Funktionstest

Funktionstest der Schließfolgeregelung:

- ▶ Gangflügel öffnen.
 - ▶ Standflügel öffnen.
 - ▶ Gangflügel schließen.
 - ▶ Standflügel schließen.
- Gangflügel bleibt in der Warteposition der Schließfolgeregelung stehen und schließt ebenfalls, wenn der Standflügel geschlossen ist.

FR | Français

Description du produit

La glissière TS 5000 ISM convient pour un montage sur des portes coupe-feu et pare-fumée à deux vantaux. L'installation comprend une régulation de fermeture en cascade. Équipement avec un TS 5000 EFS possible sur le vantail de service.

Consignes de montage

Les consignes complètent les étapes de travail du manuel de montage graphique correspondant.

- pour **1** ▶ Percer des trous de fixation pour le ferme-porte et la glissière.
- pour **4** ▶ Poser le câble métallique du système de régulation de la fermeture.
- pour **6** ▶ Les rondelles et les encoches ne doivent pas être dans une issue. Veillez à ce que le câble métallique ne soit pas coincé.
- pour **8** ▶ Dévisser légèrement les vis. La tige de murée ne doit pas basculer sous la clavette d'entraînement.

Test de fonctionnement

Test de fonctionnement de la régulation de fermeture en cascade :

- ▶ Ouvrir le vantail de service.
- ▶ Ouvrir le vantail fixe.
- ▶ Fermer le vantail de service.
- ▶ Fermer le vantail fixe.

Le vantail de service reste dans la position d'attente de la régulation de fermeture en cascade et se ferme également lorsque le battant fixe est fermé.

EN | English

Product description

The TS 5000 ISM glide rail is approved for installation on double-leaf fire and smoke protection doors. The system features integrated closing sequence control. Equipping with TS 5000 EFS on the Active leaf possible.

Installation details

The following remarks are intended as work instructions as well as the associated graphical installation instructions.

- to **1** ▶ Drill fixing holes for door closer and guide rail.
- to **4** ▶ Install the cable of closing sequence control.
- to **6** ▶ The pane and groove must be properly aligned. Ensure that the wire cable is not pinched.
- to **8** ▶ Loosen the screws slightly. The buffer stop rod under the driver must not tilt.

Functional test

Functional test of closing sequence control:

- ▶ Open active leaf.
 - ▶ Open fixed leaf.
 - ▶ Close active leaf.
 - ▶ Close fixed leaf.
- Active leaf remains in the waiting position of closing sequence control and also closes when fixed leaf is closed.

ES | Español

Descripción del producto

La guía deslizante TS 5000 ISM está homologada para el montaje en puertas de dos hojas protectoras contra humos o contra incendios. El equipo contiene una regulación integrada de la secuencia de cierre. Opción de equipamiento con TS 5000 EFS en la hoja activa.

Indicaciones de montaje

Las indicaciones complementan los pasos de trabajo de las instrucciones gráficas de instrucciones de instalación.

- de **1** ▶ Taladrar los orificios de fijación para el cierrapuertas y, la guía deslizante.
- de **4** ▶ Tender el cable metálico de la regulación de la secuencia de cierre.
- de **6** ▶ La placa y la muesca deben estar alineadas. Procure que el cable metálico no quede aprisionado.
- de **8** ▶ Aflojar ligeramente los tornillos. La varilla de tope no debe inclinarse bajo el tope de arrastre.

Prueba de funcionamiento

Prueba de funcionamiento regulación de la secuencia de cierre:

- ▶ Abrir la hoja activa.
- ▶ Abrir la hoja pasiva.
- ▶ Cerrar la hoja activa.
- ▶ Cerrar la hoja pasiva.

La hoja activa queda parada en la posición de espera de la regulación de secuencia de cierre, y cierra igualmente, cuando la hoja pasiva está cerrada.

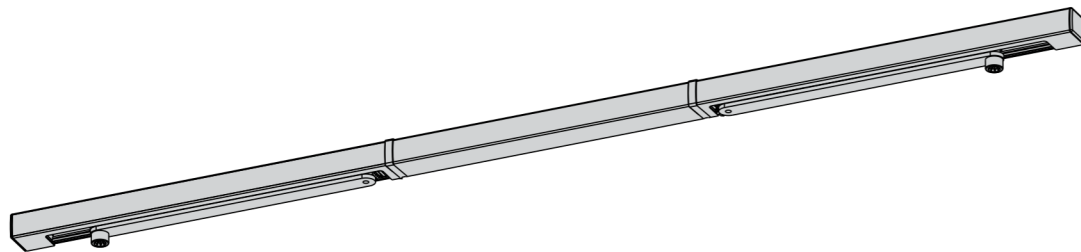

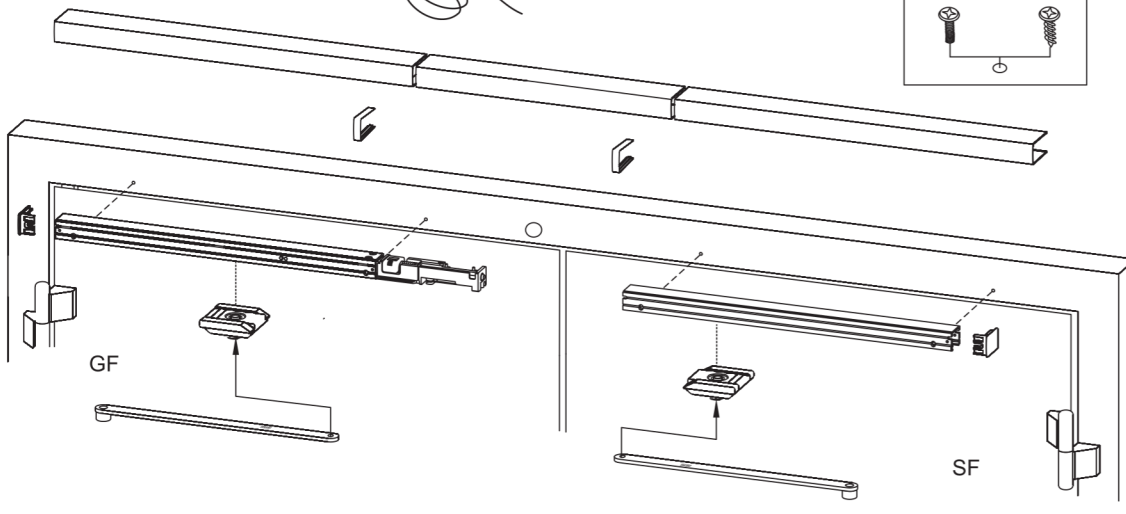
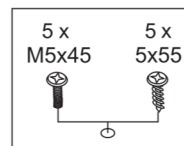

TS 5000 ISM

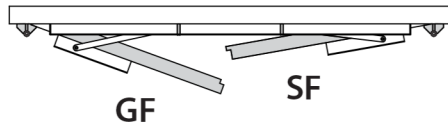



TS 5000 ISM

| | | |
|--------------------|---|---|
| TS 5000 EFS 3-6 |  |  |
| GF | GF | SF |
| (✓) | (✓) | (✓) |

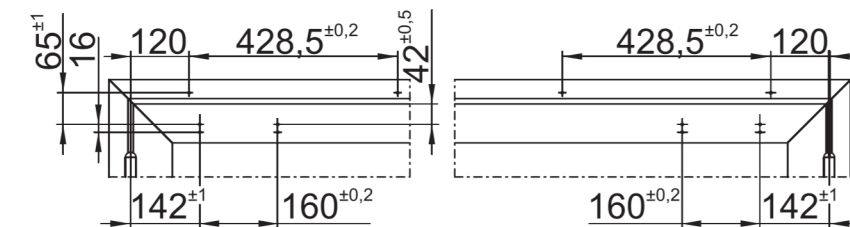
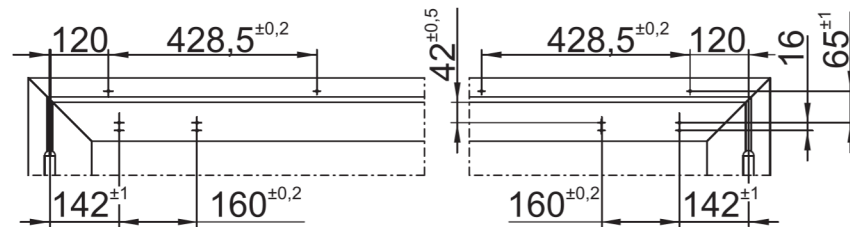
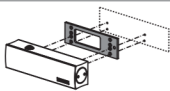
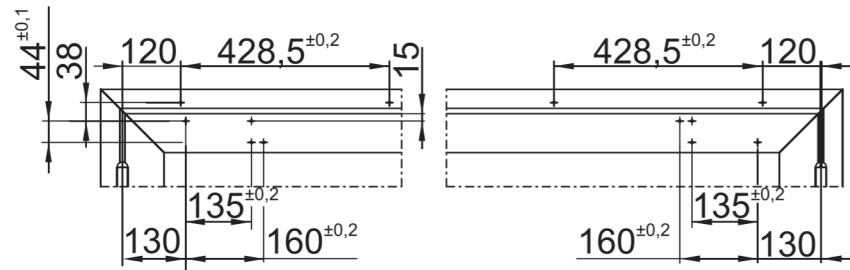
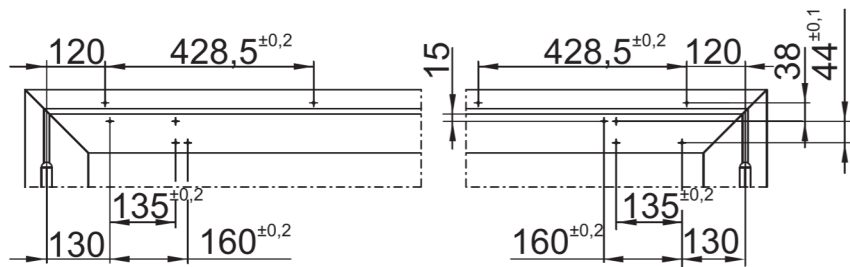
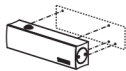

2

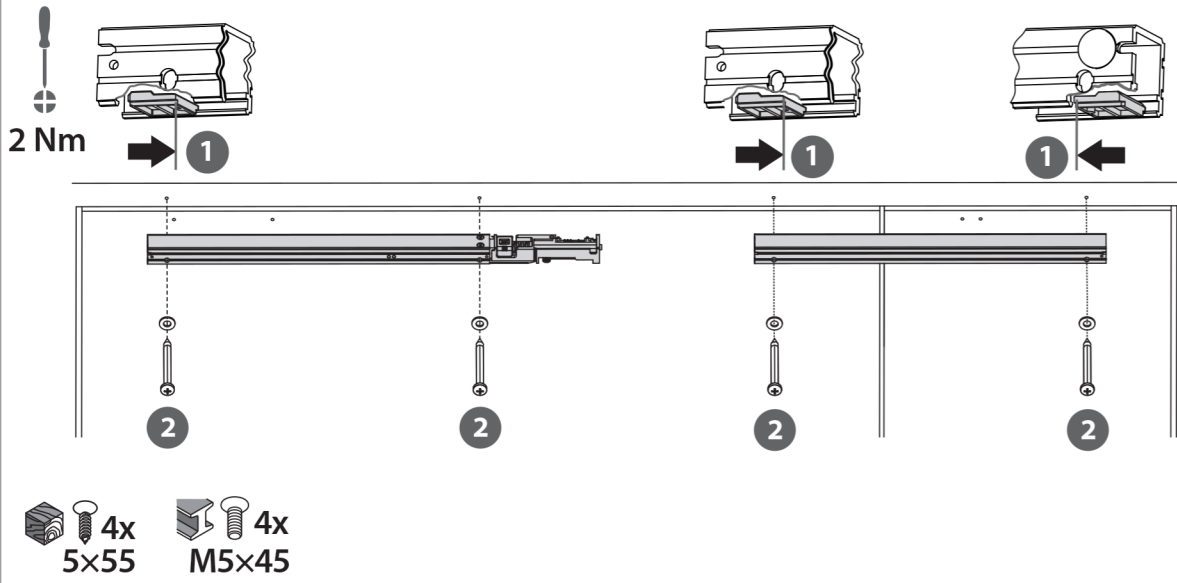

3

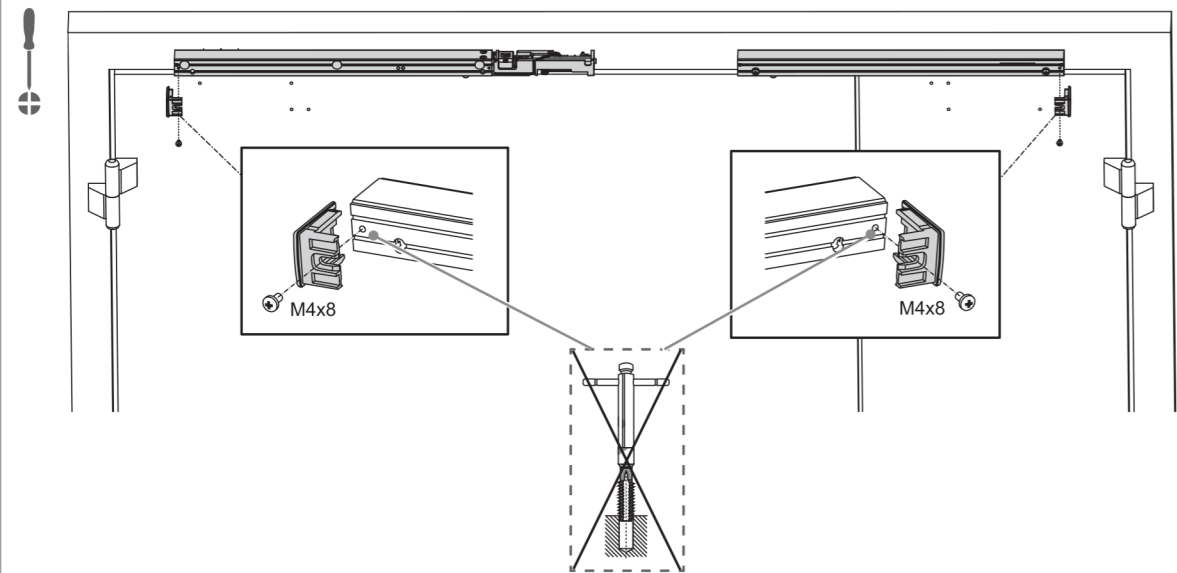

4

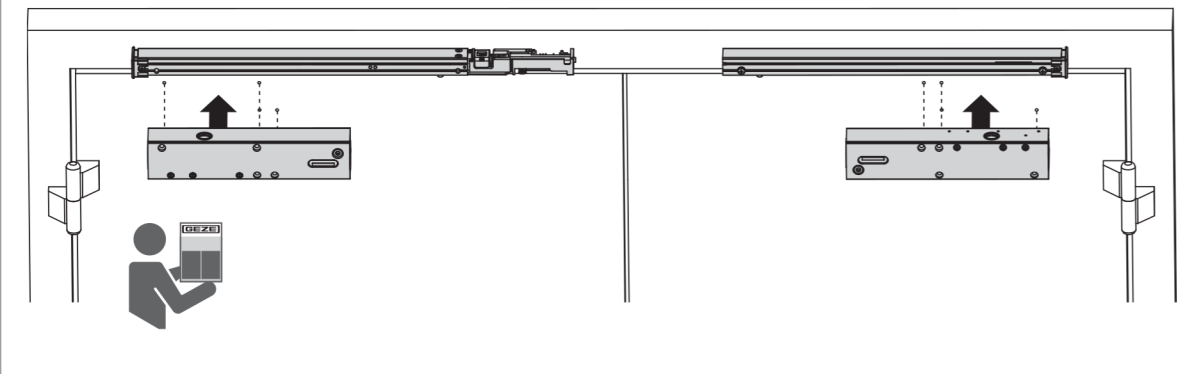

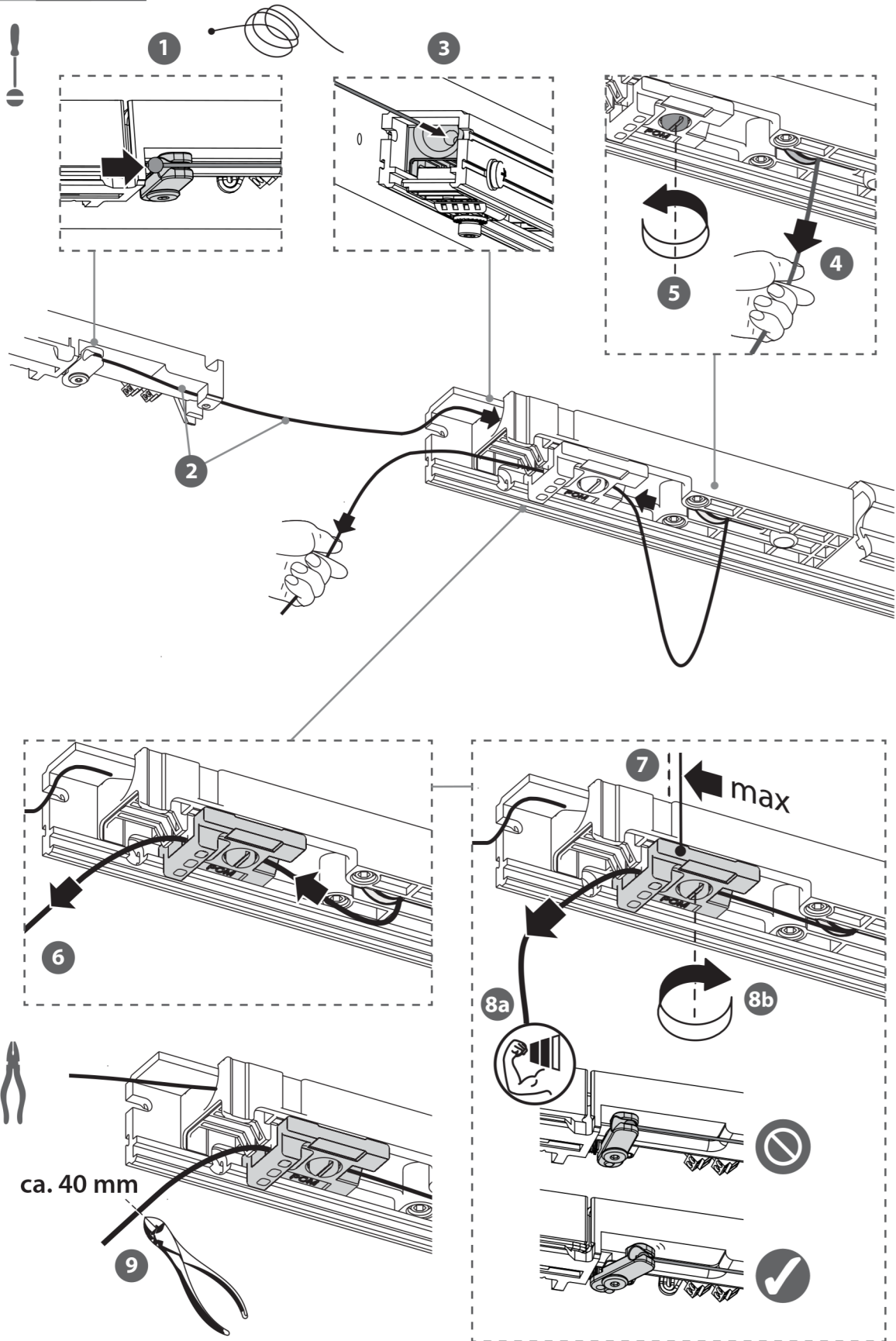

6

3 mm
5 mm

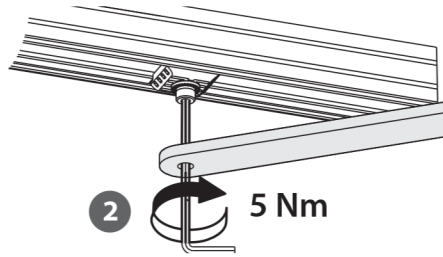
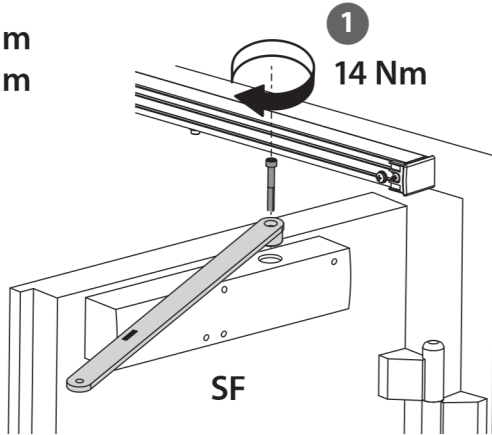

7

i+ 2

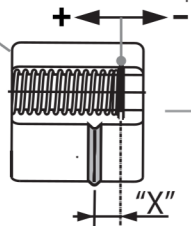
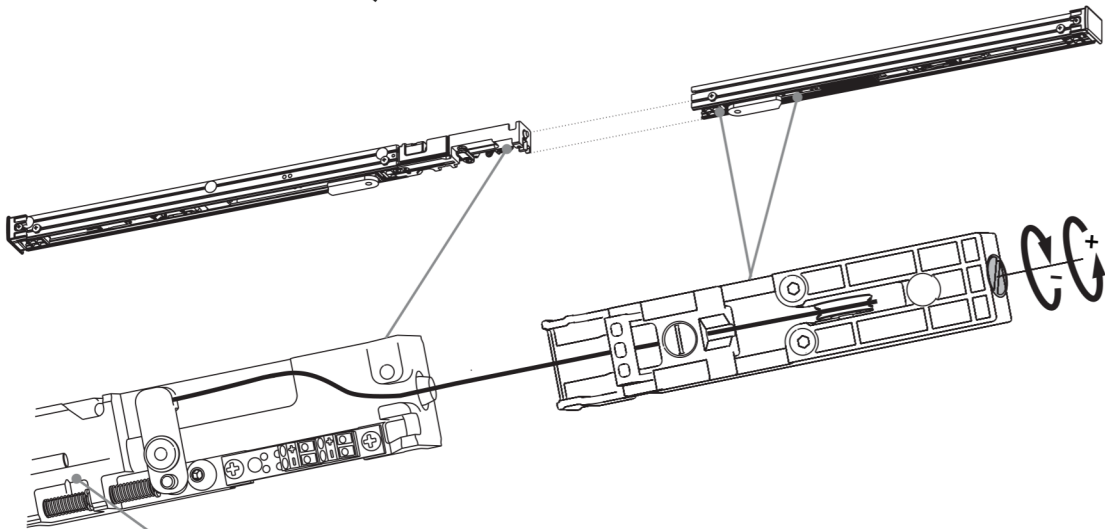
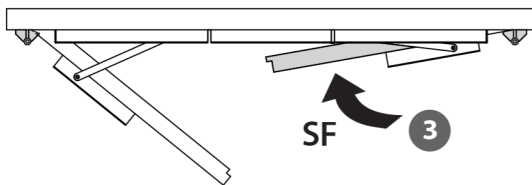

1 x = ± 1 mm

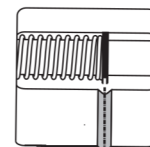

8

3 mm
5 mm

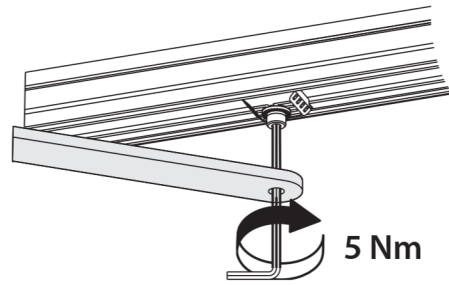
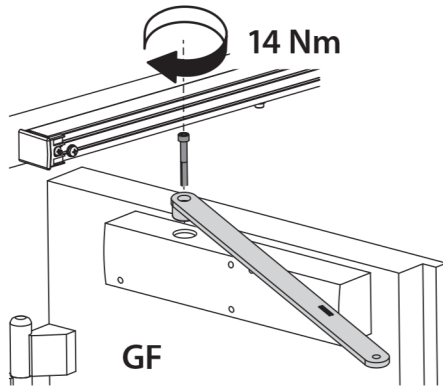

GF

9 **i+**

2,5 mm

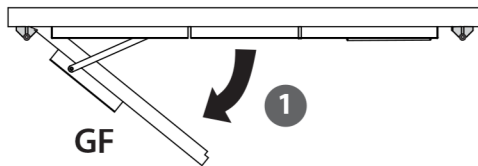

GF

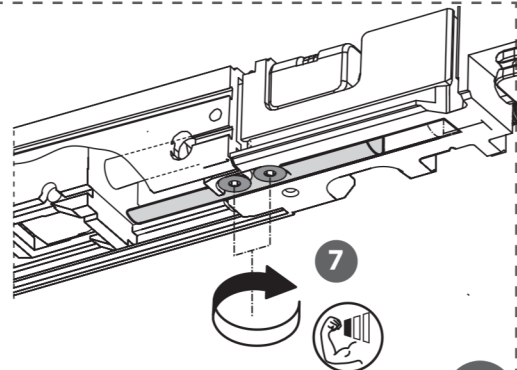
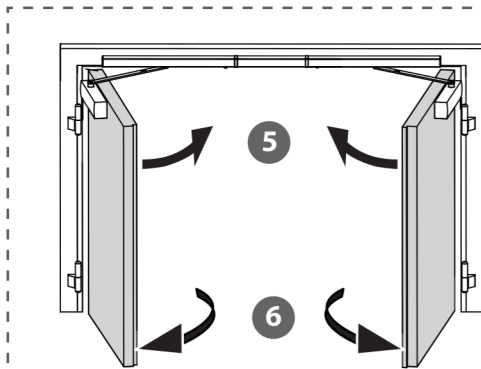
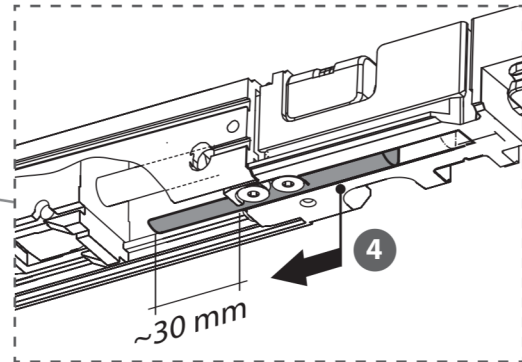
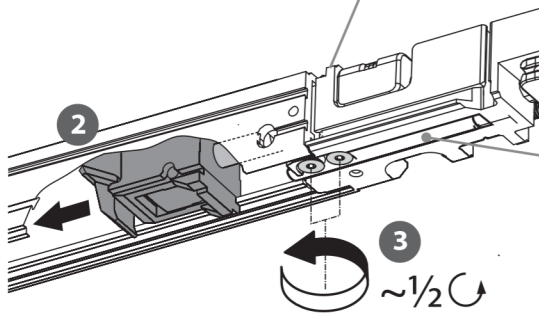
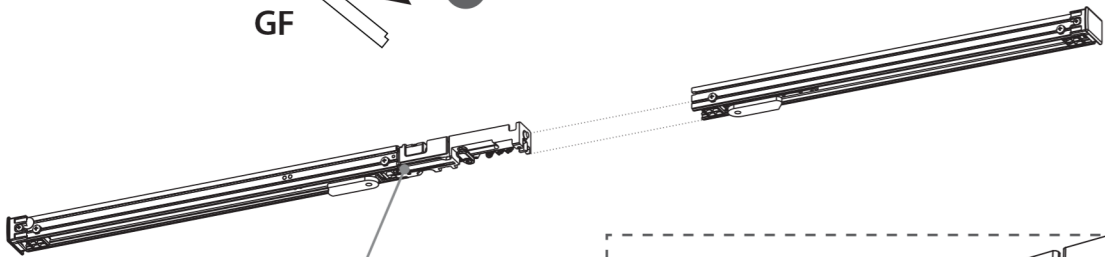

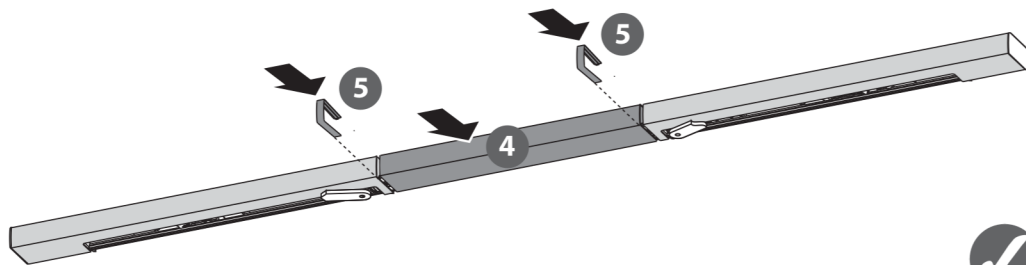
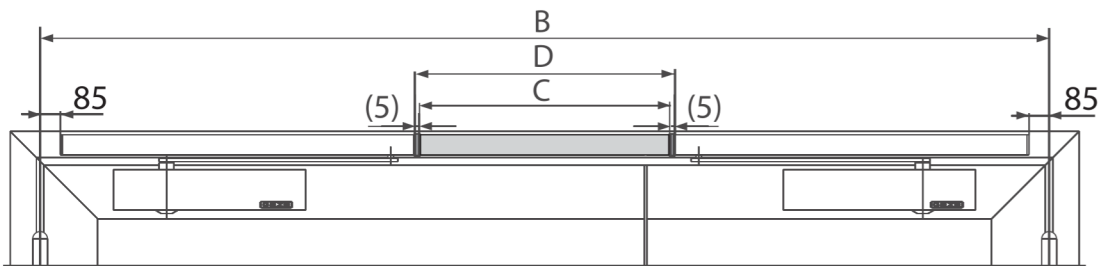
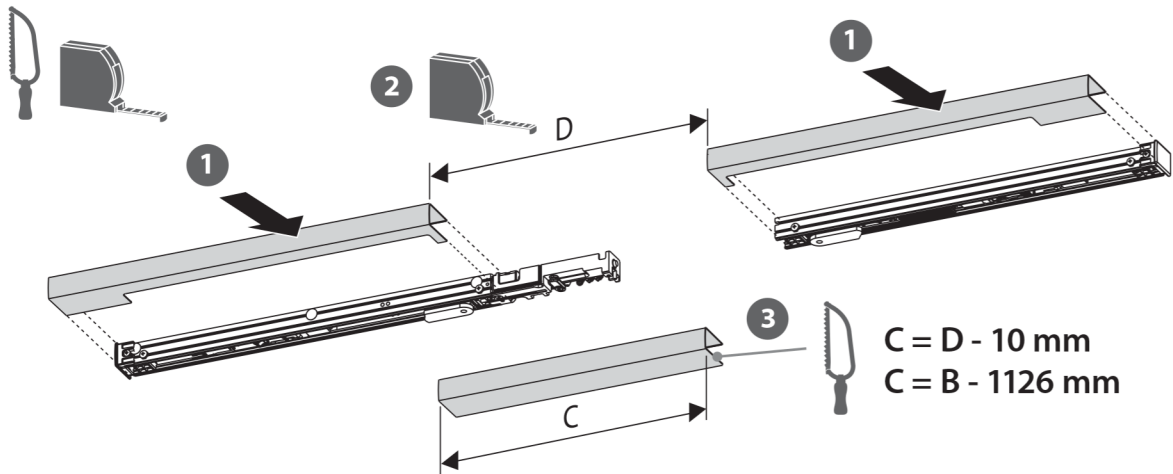

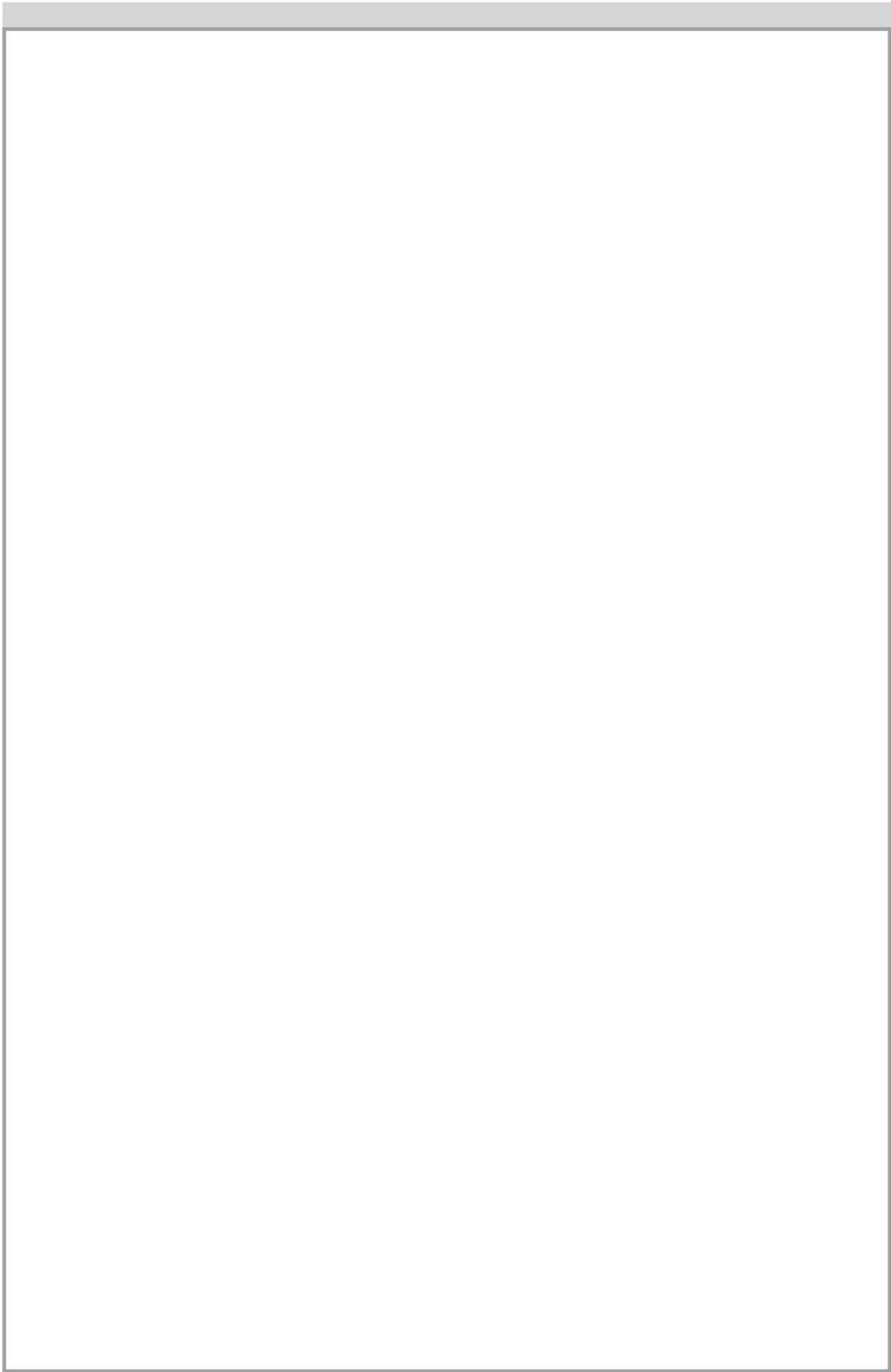

Germany

GEZE Sonderkonstruktionen
GmbH
Planken 1
97944 Boxberg-Schweigern
Tel. +49 (0) 7930 9294 0
Fax +49 (0) 7930 9294 10
E-Mail: sk.de@geze.com

GEZE GmbH
Niederlassung Süd-West
Tel. +49 (0) 7152 203 594
E-Mail: leonberg.de@geze.com

GEZE GmbH
Niederlassung Süd-Ost
Tel. +49 (0) 7152 203 6440
E-Mail: muenchen.de@geze.com

GEZE GmbH
Niederlassung Ost
Tel. +49 (0) 7152 203 6840
E-Mail: berlin.de@geze.com

GEZE GmbH
Niederlassung Mitte/Luxemburg
Tel. +49 (0) 7152 203 6888
E-Mail: frankfurt.de@geze.com

GEZE GmbH
Niederlassung West
Tel. +49 (0) 7152 203 6770
E-Mail: duesseldorf.de@geze.com

GEZE GmbH
Niederlassung Nord
Tel. +49 (0) 7152 203 6600
E-Mail: hamburg.de@geze.com

GEZE Service GmbH
Tel. +49 (0) 1802 923392
E-Mail: service-info.de@geze.com

Austria

GEZE Austria
E-Mail: austria.at@geze.com
www.geze.at

Baltic States

GEZE GmbH Baltic States office
E-Mail: office-latvia@geze.com
www.geze.com

Benelux

GEZE Benelux B.V.
E-Mail: benelux.nl@geze.com
www.geze.be
www.geze.nl

Bulgaria

GEZE Bulgaria - Trade
E-Mail: office-bulgaria@geze.com
www.geze.bg

China

GEZE Industries (Tianjin) Co., Ltd.
E-Mail: chinasales@geze.com.cn
www.geze.com.cn

GEZE Industries (Tianjin) Co., Ltd.
Branch Office Shanghai
E-Mail: chinasales@geze.com.cn
www.geze.com.cn

GEZE Industries (Tianjin) Co., Ltd.
Branch Office Guangzhou
E-Mail: chinasales@geze.com.cn
www.geze.com.cn

GEZE Industries (Tianjin) Co., Ltd.
Branch Office Beijing
E-Mail: chinasales@geze.com.cn
www.geze.com.cn

France

GEZE France S.A.R.L.
E-Mail: france.fr@geze.com
www.geze.fr

Hungary

GEZE Hungary Kft.
E-Mail: office-hungary@geze.com
www.geze.hu

Iberia

GEZE Iberia S.R.L.
E-Mail: info@geze.es
www.geze.es

India

GEZE India Private Ltd.
E-Mail: office-india@geze.com
www.geze.in

Italy

GEZE Italia S.r.l.
E-Mail: italia.it@geze.com
www.geze.it

GEZE Engineering Roma S.r.l.
E-Mail: roma@geze.biz
www.geze.it

Poland

GEZE Polska Sp.z o.o.
E-Mail: geze.pl@geze.com
www.geze.pl

Romania

GEZE Romania S.R.L.
E-Mail: office-romania@geze.com
www.geze.ro

Russia

OOO GEZE RUS
E-Mail: office-russia@geze.com
www.geze.ru

Scandinavia – Sweden

GEZE Scandinavia AB
E-Mail: sverige.se@geze.com
www.geze.se

Scandinavia – Norway

GEZE Scandinavia AB avd. Norge
E-Mail: norge.se@geze.com
www.geze.no

Scandinavia – Denmark

GEZE Danmark
E-Mail: danmark.se@geze.com
www.geze.dk

Singapore

GEZE (Asia Pacific) Pte, Ltd.
E-Mail: gezesea@geze.com.sg
www.geze.com

South Africa

GEZE Distributors (Pty) Ltd.
E-Mail: info@gezesa.co.za
www.geze.co.za

Switzerland

GEZE Schweiz AG
E-Mail: schweiz.ch@geze.com
www.geze.ch

Turkey

GEZE Kapı ve Pencere Sistemleri
E-Mail: office-turkey@geze.com
www.geze.com

Ukraine

LLC GEZE Ukraine
E-Mail: office-ukraine@geze.com
www.geze.ua

United Arab Emirates/GCC

GEZE Middle East
E-Mail: gezeme@geze.com
www.geze.ae

United Kingdom

GEZE UK Ltd.
E-Mail: info.uk@geze.com
www.geze.com

GEZE GmbH

Reinhold-Vöster-Straße 21–29
71229 Leonberg
Germany

Tel.: 0049 7152 203 0
Fax.: 0049 7152 203 310
www.geze.com

